

IDENTIFICATION

WEBB Air Disc Brake Calipers are identified by the part number which is marked on the ID plate.

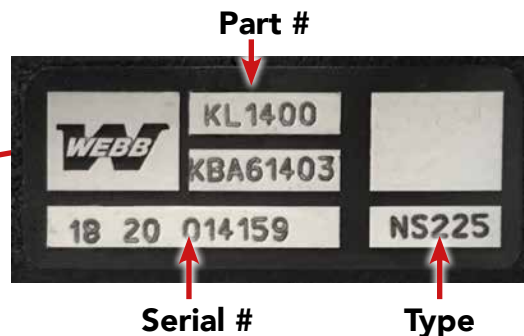

After a long life in service or while still on the vehicle it can be difficult to read the information on the ID plate. Therefore the following can be useful in assisting identification.

- Looking from the air chamber side (rear), if there are bolts visible as shown, the brake is an MC225 typically used on trucks, trailers and some motor coach vehicles. If there are no bolts the brake is an NS225 typically used on transit buses and other specialized applications.

MC225 - two visible bolts near short and long guide sleeve ports

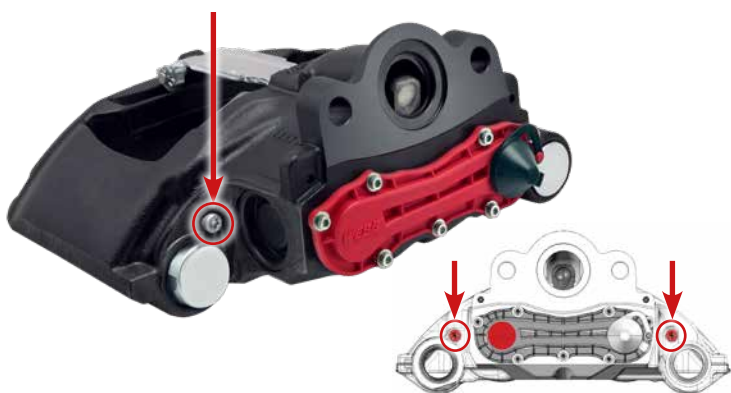

NS225 - no bolts visible



- Next, check the air chamber mounting angle. This ranges from "0" degree to "+12" degree.

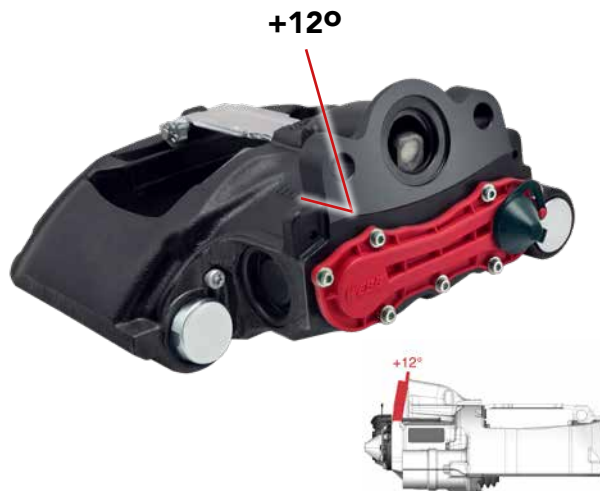
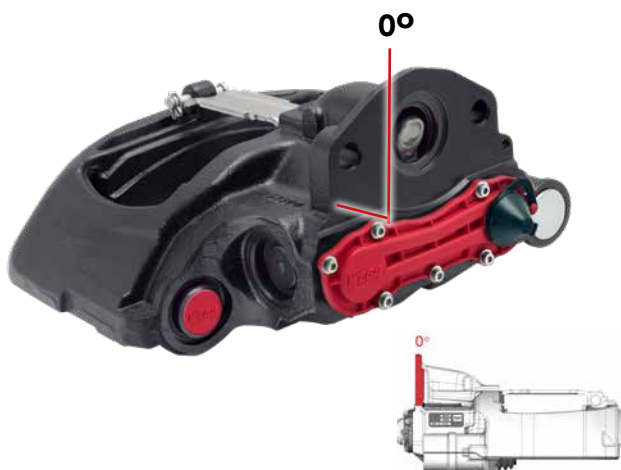

IDENTIFICATION

3 Next, check if the Long Guide Sleeve is on Left or Right as shown.



4 Check the chain cover to determine if it is plain or includes a sensor.

